



Intended Use

- The Special Tomato EIO Pushchair is a Pushchair that provides mild to moderate positioning support for children with special needs. It offers typical features for a lightweight Pushchair, including several adjustment options, accessories, a brake mechanism, and the ability to fold for easy transport.

Environment of Use

- The EIO Push Chair is intended for both indoor and outdoor use, in the home and community. If used in the rain, wipe off excess water with a soft cloth. If the chair is splashed with mud or corrosive substances like road salt, the chair should be washed clean with water, wiped dry, and a hypoallergenic and biodegradable lubricant reapplied to the moving parts. Contact with seawater should be avoided, as it will corrode areas that cannot be washed clean. When going from outside to inside, clean any excess dirt or mud from the wheels to prevent soiling of inside environment.
- Remember to NEVER use WD-40 or silicone-based lubricants on the EIO Push Chair
-  **Warning:** Avoid prolonged exposure to extreme heat or cold, including saunas. Always check temperature of chair before use.

Table of Contents

Intended Use	2
Environment of Use	2
General Information and Safety	3
Maintenance	4
Cleaning	5
Included Parts	5
Optional Accessories	5
Dimensions and Sizing Chart	6
Assembly & Fitting	7
1. Frame.....	7
2. Rear axle	7
3. Rear wheels.....	7
4. Front wheels	7
5. Footrest.....	7
6. Seat fabric	8
7. Canopy	9
8. Padded laterals (x4)	10
9. Seat belt / shoulder harness / foot block operation	10
11. Parking brake	11
12. Recline strap	11
13. Footwell angle	11
14. Front wheel swivel locks	11
Folding	12
Lifting	13
Limited Warranty	14

General Information and Safety

⚠️ WARNING: AVOID SERIOUS INJURY FROM FALLING OR SLIDING OUT. ALWAYS USE THE SEAT HARNESS. NEVER LEAVE CHILD UNATTENDED. KEEP THESE INSTRUCTIONS FOR FUTURE REFERENCE. A CHILD'S SAFETY IS YOUR RESPONSIBILITY. THIS PUSH CHAIR IS SUITABLE FOR ONE CHILD.

- Follow all instructions carefully and keep this user manual for future reference. Incorrect use can cause injury or damage to push chair.
- Children should be harnessed in at all times and should never be left unattended.
- The harness is not a substitute for proper adult supervision.
- **IMPORTANT - It is important for your child's safety that the harness be correctly fitted and adjusted. The stability of the push chair can be compromised if the safety harness is not adjusted correctly in accordance with these instructions.**
- Keep child clear of any moving parts while making adjustments.
- **IMPORTANT - DANGER: Ensure that children are kept clear of the push chair when folding or unfolding. Pinch points and scissoring actions are unavoidable during these operations.**
- Do not carry additional children, goods, or accessories in or on the push chair except as permitted in this manual. They may cause the push chair to become unstable or place unneeded stress on the push chair that could lead to damage.
- Overloading beyond 90lbs (40kg), incorrect folding, or the use of accessories, e.g. child seats, bag hooks, rain covers, buggy boards, etc., other than those approved by the manufacturer may damage the push chair.
- Never leave child in the push chair when ascending or descending stairs or escalators or when travelling on other forms of transport.
- Negotiate curbs and rough ground with care. Repeated impact can cause damage to the push chair.
- **Never allow children to stand on the footrest.**
- Do not place items on the top of the canopy as it may cause damage to the canopy.
- The EIO should always fold and unfold easily. Do not force.
- **ALWAYS APPLY THE PARKING BRAKE WHEN THE PUSH CHAIR IS STATIONARY.**
- Keep away from open flames*
- **Attendant must use hand tether strap (included) at all times.**
- **WARNING: Not for use in a motor vehicle.**

* Resistance to ignition of upholstered parts complies to BS-EN 1021-1 and -2

Maintenance

This push chair requires regular maintenance by the user. Before each use, check all rivets and connecting devices for tightness. Inspect brakes, wheels, and tires and replace or repair if necessary. Check all safety devices for correct operation. **Immediately** discontinue use of push chair if it is not structurally sound.

Axles and moving parts should be wiped off **weekly** with a damp cloth to remove dust, dirt, and mud. Sparingly apply a high quality Teflon spray after each cleaning. **DO NOT USE** WD-40, silicone sprays, or other lubricant sprays that will attract dust and dirt.

Repair or replace any loose, worn, bent, missing, or damaged parts before using the push chair. Only manufacturer replacement parts should be used. It may be unsafe to use parts not supplied by manufacturer.

Maintenance Checks	Weekly	Every 3 months	Every 6 months	As necessary
Rims and tires	•			
Wheel locks	•			
Accessories	•			
Front and rear wheel axles	•			
Clean/lubricate all moving parts ¹	•			
Belts, zippers, and hook-and-loop closures		•		
Seat/back upholstery ² and tautness		•		
Armrests & foam			•	
Frame			•	
Contacting a Special ³ Tomato dealer for service or repair				•

¹ Note: Do NOT use WD-40 or silicone-based spray as a lubricant.

² Follow cleaning instructions for appropriate user hygiene

³ Note: Repair or replacement of non-removable, worn, or broken parts must be performed by a qualified service facility.

Cleaning

- Clean frame with a damp cloth and a mild detergent and dry thoroughly.
- The canopy may be sponged lightly using a damp cloth and a mild detergent. The seat fabric, head cushion, lateral pads and harness pads may be washed. Line dry thoroughly before reuse. Gray Harness can be placed in a mesh bag and machine washed on gentle cycle only.
- Do not fold or store the product while wet and never store in a damp environment; this can cause mildew to form.
- The EIO seat fabric can be machine washed on gentle cycle in cold water with a mild detergent. To minimize shrinkage, simply reattach the seat fabric to the frame to dry. (DO NOT put seat fabric in the dryer)
- Be sure to unzip and remove all three rigid boards from the seat fabric before washing (see arrows to the right).

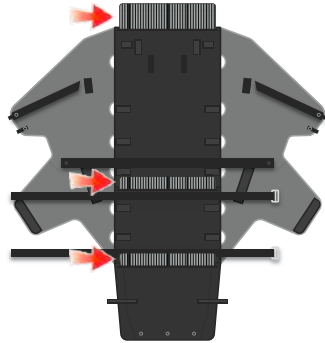

Parts Included



Optional Accessories



EIO Rain Cover



Soft-Touch Sitter



Soft-Touch Liners

Dimensions and Sizing Chart

Target User Height (approx.)	30 - 50" (76.5 - 127 cm)
Seat Width	14" (35.5 cm)
Seat Width - Pads at Most Narrow Point	9" (22.9 cm)
Seat Depth	12" (30.5 cm)
Seat Back Height	24" (61 cm)
Seat to Footwell - Stroller Only	13" (33 cm)
Seat to Footwell - with Size 1 or 2 Liners	15" (38 cm)
Seat to Footwell - with Size 1 Sitter	16" (40.6 cm)
Seat to Footwell - with Size 2 Sitter	17" (43 cm)
Floor to Seat Height (Front) - inches (cm)	20" (50.8 cm)
Floor to Seat Height (Back) - inches (cm)	16" (40.6 cm)
Handle Height to Floor - inches (cm)	30" - 42" (76 - 106.7 cm)
Maximum Weight Capacity	90 lbs (40 kg)
Weight of Push Chair	22 lbs (10 kg)
Shoulder Harness Height Levels	9" 11" 13.5" 16"
Seat Recline Range (from upright)	25° - 75 °
Overall Dimensions (width x length x height)	24" x 46" x 45" (61 x 117 x 114 cm)
Folded Dimensions (width x length x height)	24" x 43 " x 20" (61 x 109 x 51 cm)
Folded Dimensions without Rear Wheels (width x length x height)	22" x 37 " x 20" (55.9 x 94 x 51 cm)
Wheel Diameter (front & back)	9" & 11 " (22.9 x 27.9 cm)
Serial #	00896688001855

Assembly & Fitting

1. FRAME

Open frame in the upright position.

When primary & secondary lock is engaged, an audible CLICK will be heard.

NOTE: Rigid inserts may be removed from the shopping pocket.

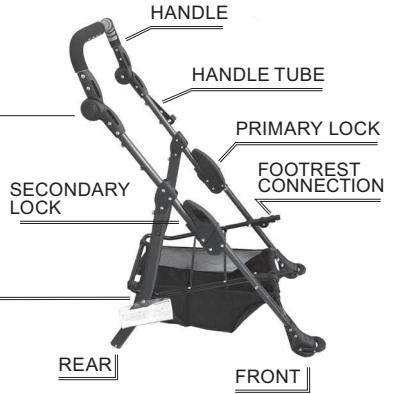

2. REAR AXLE

Push rear frame legs into rear axle.

When lock is engaged, an audible CLICK will be heard.



3. REAR WHEELS

Push rear wheel onto rear axle (right and left sides).

When wheel is attached, an audible CLICK will be heard.



4. FRONT WHEELS

Push front wheel up into front frame leg (right and left sides).

When front wheel is attached, an audible CLICK will be heard.



5. FOOTREST

Orient footrest so that it is facing up. Push right and left footrest tubes into the frame at the same time.

When lock is engaged, an audible CLICK will be heard.



Note: Visit our YouTube channel for instructive and informative videos!

6. SEAT FABRIC

Double button on the handle tube (right & left sides).

When button is engaged, an audible SNAP will be heard.

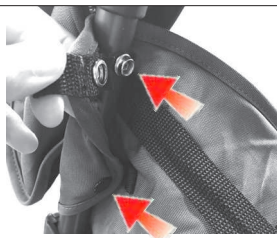

6A. SEAT FABRIC

Button support straps to each rear leg.

When button is engaged, an audible SNAP will be heard.

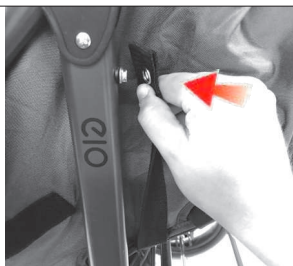

6B. UNDER SEAT FRAME STRAPS (x2)

FRONT STRAP
(above bolt, below
footwell adjustment)

REAR STRAP



6C. IMPORTANT: UNDER SEAT STRAP D-RINGS

Thread up through the bottom, then down through the top.

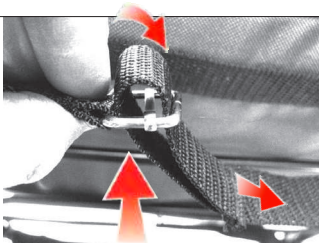

6D. UNDER SEAT STRAP D-RINGS

Loose tail of under seat strap should be positioned between the taught strap and the seat bottom.

DO NOT overtighten.



6E. FOOTWELL SNAPS (×2)

Button footwell fabric to footwell snaps.

When button is engaged, an audible SNAP will be heard.



6F. FOOTWELL VELCRO (×2)

Wrap velcro around footwell frame and fasten (right and left sides).



6G. SIDE SADDLE POCKETS

Fold over primary frame locks and velcro down (right and left sides).



7. CANOPY

- A** Slide canopy clip down into frame connector (right and left sides). **DO NOT** force. Be sure clip is clear of fabric obstruction.

When lock is engaged, an audible CLICK will be heard.

- B** To remove canopy, press down clip then slide upward.

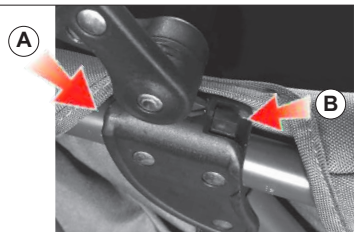

CANOPY SNAP & ZIPPER

Fasten stabilization snaps and zipper the canopy sides (right and left sides). Zipper and snap should be positioned just below the handle adjustment button.

NOTE: You can remove the rear half of the canopy by unzipping the center seam.



8. PADDED LATERALS (×4)

Feed both hook-and-loop straps through slots located at the edges of seat & back surface.

Pull hook-and-loop straps through to the outside of the seating (or back) surface. Then wrap around frame and fasten.

Repeat for all straps.

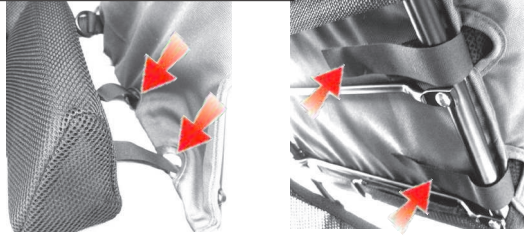

ATTENDANT TETHER STRAP

Attach Tether Strap to handle bar.

Ensure safety wrist strap is secured properly around your wrist whenever EIO is in use.



9. PELVIC HARNESS / SHOULDER HARNESS / FOOT BLOCK OPERATION



WARNING: Avoid serious injury from falling or sliding out.

Always use the crotch strap in combination with the waist belt and shoulder straps.

9.A HEIGHT-ADJUSTABLE SHOULDER STRAPS

Unclip chest pad clip then feed straps down through backrest loops to adjust the shoulder strap anchor point. Reconnect chest pad clip.

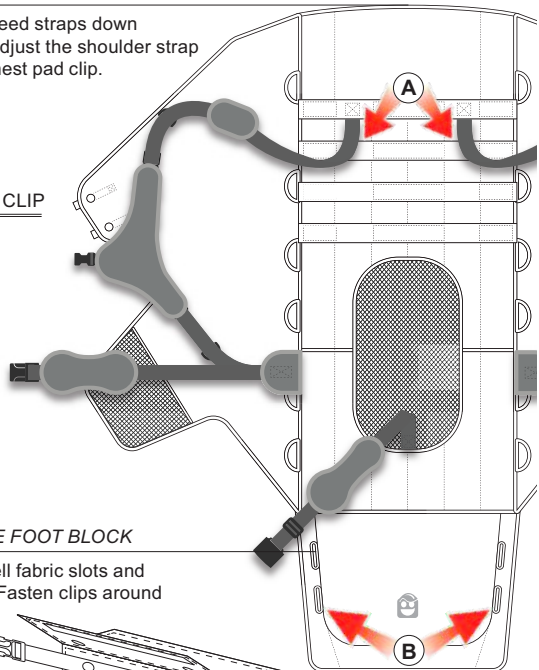
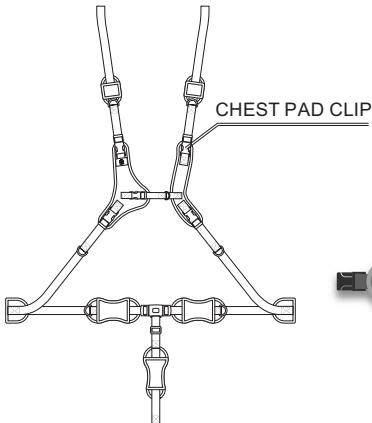

9.B HEIGHT-ADJUSTABLE FOOT BLOCK

Feed straps through footwell fabric slots and around the footwell frame. Fasten clips around the back side and tighten.

See installed on next page.

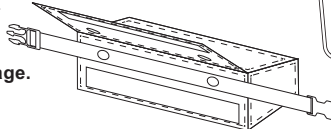

9.B HEIGHT-ADJUSTABLE FOOT BLOCK (cont.)

Foot block shown installed.

NOTE: Block can be adjusted higher or lower.

Feed strap around outside of frame.



11. PARKING BRAKE

Using foot, push up to disengage the parking brake and press down to engage the parking brake.

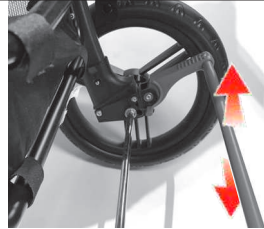

12. RECLINE STRAP

Press button on buckle and slide up or down to adjust recline.



13. FOOTWELL ANGLE

To adjust footwell angle, press the angle lock button on both sides simultaneously.

When lock is engaged, an audible CLICK will be heard.



14. FRONT WHEEL SWIVEL LOCKS

To engage front wheel swivel locks, press tab down. To allow front wheels to swivel freely, pull tab up. Repeat on both sides.

When lock is engaged, an audible CLICK will be heard.

NOTE: For lock to engage, front wheels must be facing forward.



Folding

⚠ Warning: Moving parts present risk of pinching. The push chair should always fold and unfold easily. Do not force.

- (A)** Fully recline push chair backrest.
- (B)** Disengage rear canopy hood from seat back.
- (C)** Place handle in upright position.
- (D)** Unlock front swivel wheels (both sides facing forward).
- (E)** Standing behind the push chair, loosen safety lock on right side of stroller then pull up to release left and right frame locks.



- (F)** Frame locks will disengage.
- (G)** Push down on handle of EIO.



- (H)** Engage closure clip.

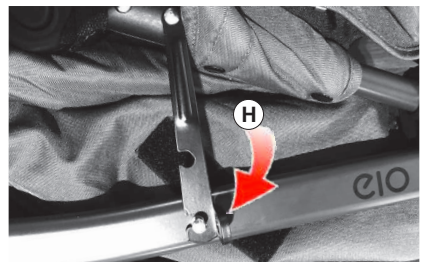

Lifting

 **Warning:** Never lift the push chair with a child in it.

To lift the push chair, firmly grasp the front tube frame above padded fabric wrap on **both** sides of EIO.



Limited Warranty

Your EIO Push Chair is guaranteed to be free from manufacturing defects for a period of 2 years from the date of purchase provided it is used in compliance with these operating instructions. This "Limited Warranty" extends only to the original retail purchaser and is only valid when supplied with proof of purchase. Please retain proof of purchase with this Limited Warranty.

Should a repair be needed please contact the retailer where the product was purchased.

Please note that the Limited Warranty will not be applicable if:

- A fault is caused by misuse or poor maintenance.
- Repairs are carried out by a third party.
- The push chair is faulty due to general wear and tear resulting from everyday use.
- The push chair is damaged as a result of an accident.
- The manufacturer is not satisfied that the stated warranty terms and conditions have been met.



318 Davis Street, Ste 1, Clarks Summit,
PA 18411, USA
info@lohmedical.com
www.lohmedical.com

The information contained
herein is subject to change
without notice.